

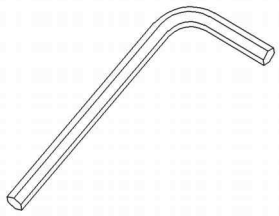

# Instructions for use of honeycomb paper dispenser

[www.AirPackagingMachine.com](http://www.AirPackagingMachine.com)

**MODEL:HP50-01**  
**VERSION:202009**



X1

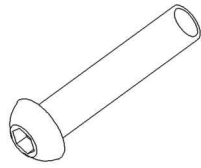

X4

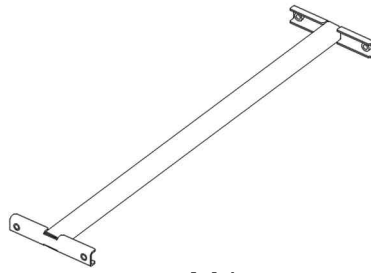

X1

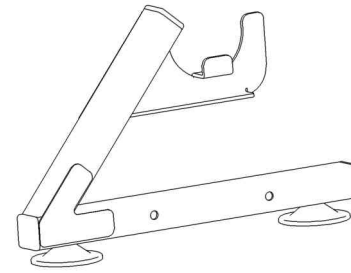

X1

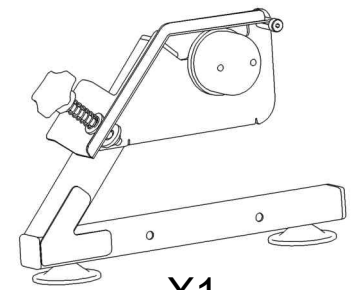

X1

①

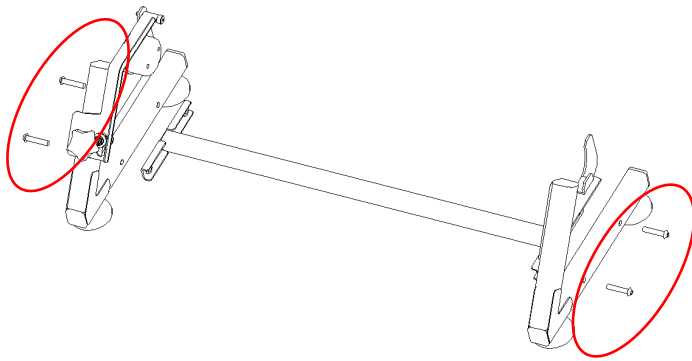

1.Pass the matching screws into the corresponding holes.

2.Then lock the left and right brackets with the middle crossbar.

②

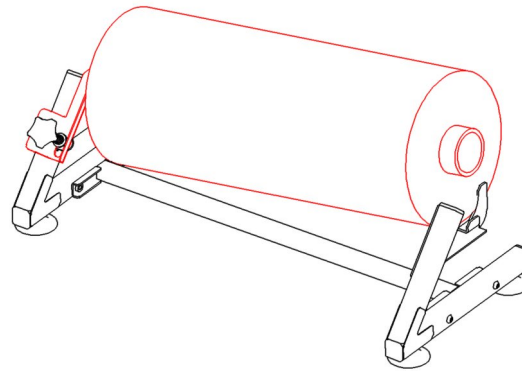

1.Lift up the honeycomb roll and put one side into the left stents.

2.After supporting one side of the honeycomb roll, lift up the pressure adjusting plate with your left hand.

[www.AirPackagingMachine.com](http://www.AirPackagingMachine.com)

③

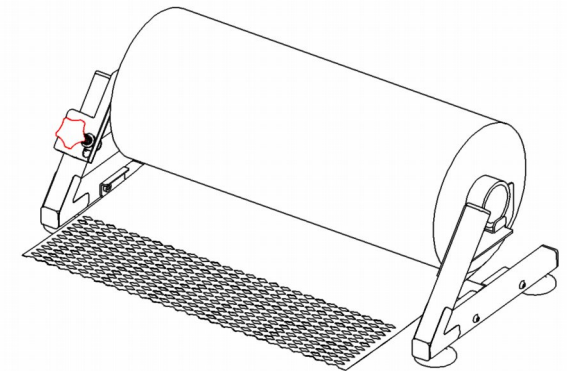

1.If the honeycomb shape cannot be pulled out for the first time, adjust the pressure knob clockwise.