

018N Air Filling Machine Operation Manual

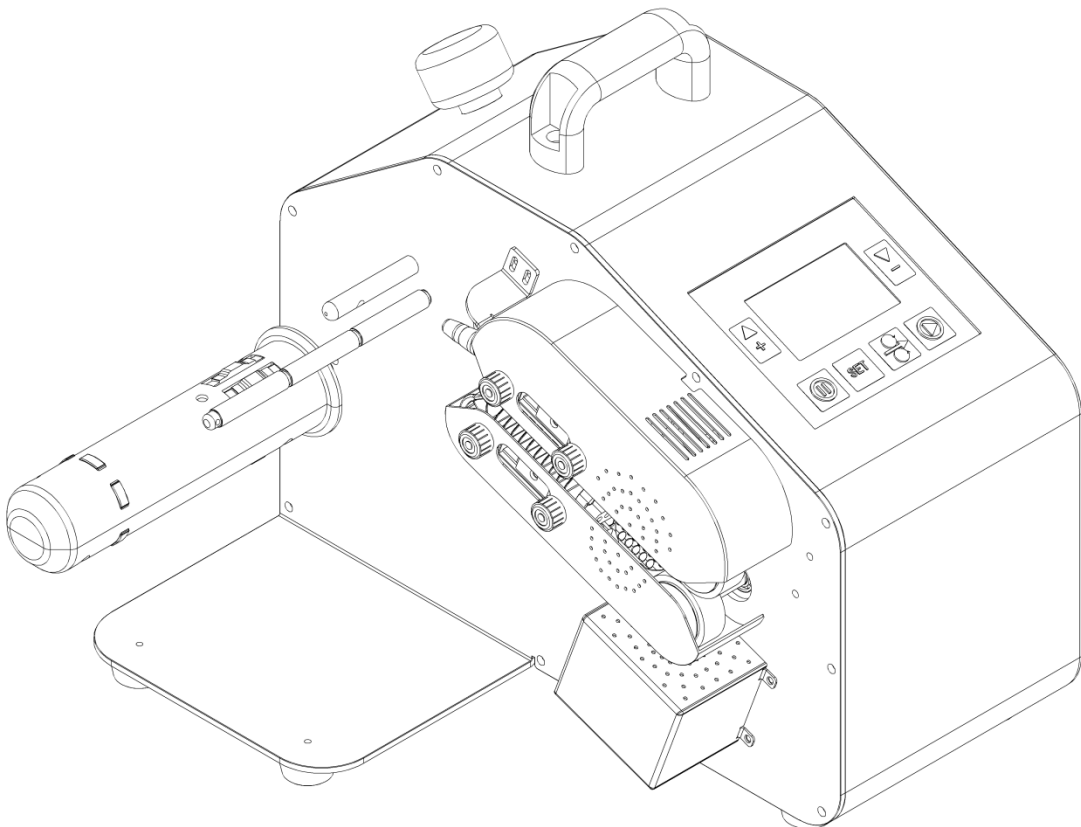

Please read the instruction manual carefully, before installing and using the product. (please keeping properly in case of use need)

1.0 About Operation Manual

This manual wrote for identify the machine parts location, interpret the system's operation and solve solution for basic malfunction.

This manual for 018N Air Filling Machine.

Special Symbol's Definition and Suggestion:



"Lightning Flash" Symbol: Not insulated parts inside the machine, touch may cause electric



"Float" Symbol :Do not use it as a float.



"Toy" Symbol :Do not use it as a toy.



"Pillow" Symbol : Do not use it as pillow.

2.0.Instructions for safe use

2.1.Important Safety Information

1.Please read carefully and understand completely all the information of this manual.

2.Please confirm the following matters before operate system:

- The authorized dealer or technicians has provided complete training to the operator.
- The operator has read and understood all the safety signs posted on the device.
- Confirm the air filling machine power part--the power source meet the demand of machine, and use with grounding device.

(please refer to 3.5: Power Request)



Warn: Improper grounding may cause electric shock.

Warn: Do not open the machine cover. the cover disassemble should done by authorized

technicians and technician trained maintenance personnel.



Warn: Be careful of rolled into the machine! when machine start to work like pull the film,inflate the film or sealing, please keep finger, hair, jewelry, and clothes away from the sealing roller.



Warn: Be careful of scalded, pay attention to the surface of the sealing roller, high temperature sealing line may cause scalded!

3. Inflatable bag should used as packing:

4. Please confirm the following matters before maintain and repair equipment:

- Turn off the power to the system and unplug it.
- Important Noted: 018N air filling machine only can used for our company's film. if use with the film not provided by our company, we have right terminate the maintenance services immediately and stop supply all the film and relative use material.



Warn: Except the description of this manual's "Maintenance&Repair", please do not attempt to repair or modify the 018N filling machine. repair should be carried out by representatives of our company, authorized distributor or professional maintenance personnel trained by our company



Warn: Please do not open the belt cover except for execute the belt replacement of this manual.

5. Check the equipment regularly to ensure

- The wires of all parts is not scratched, damaged and broken.
- No debris remains on the belt
- All control parts and display unit is operating normally.



Warn: Any inconsistent system description to the manual during use,please turn off the system immediately, unplug the power plug and contact our technical service representative.

6.Noise

018N--The maxi running noise of air filling machine-- is 95 decibels, Please confirm if this value available for the standards of local regulations.

7.Environmental Conditions

- Storage temperature: Machine:0-43°C; Film: 0-43°C
- Operating temperature: Machine 16-43°C; Film: 16-43°C



Warn: The film can only work well(good seal effect) when placed at the above temperatures parameter range, if storage in the environment exceed/below above temperature range, might caused the film broken.

8.Potential risks

Even though most of part of 018N equipped with belt cover,still some parts not been covered,please be careful during operation.

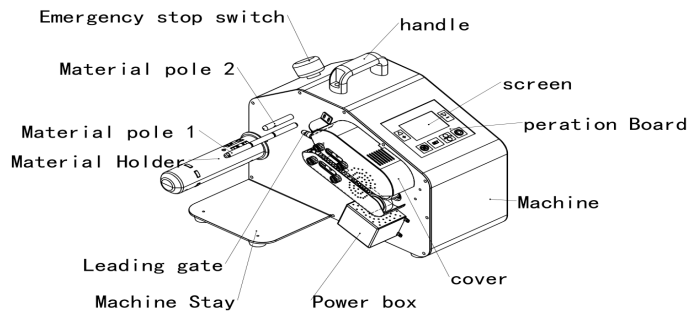

Pic 1 (Product full figure)

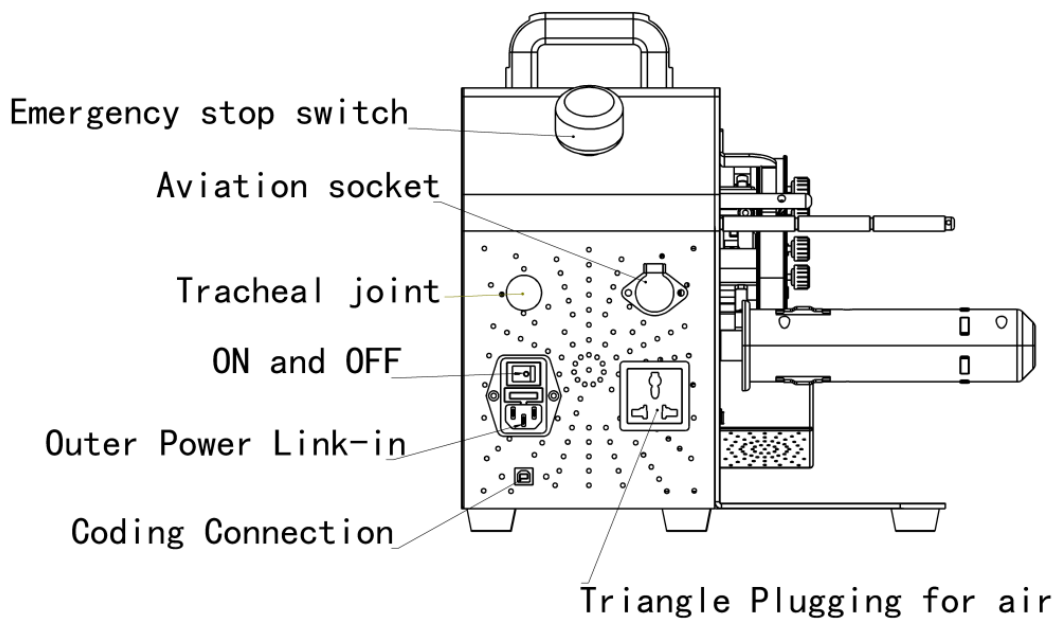

Note: standard configuration do not equipped with aviation socket, three-hole socket and An external gas source,need purchase additionally.

Pic 2(machine rear view)

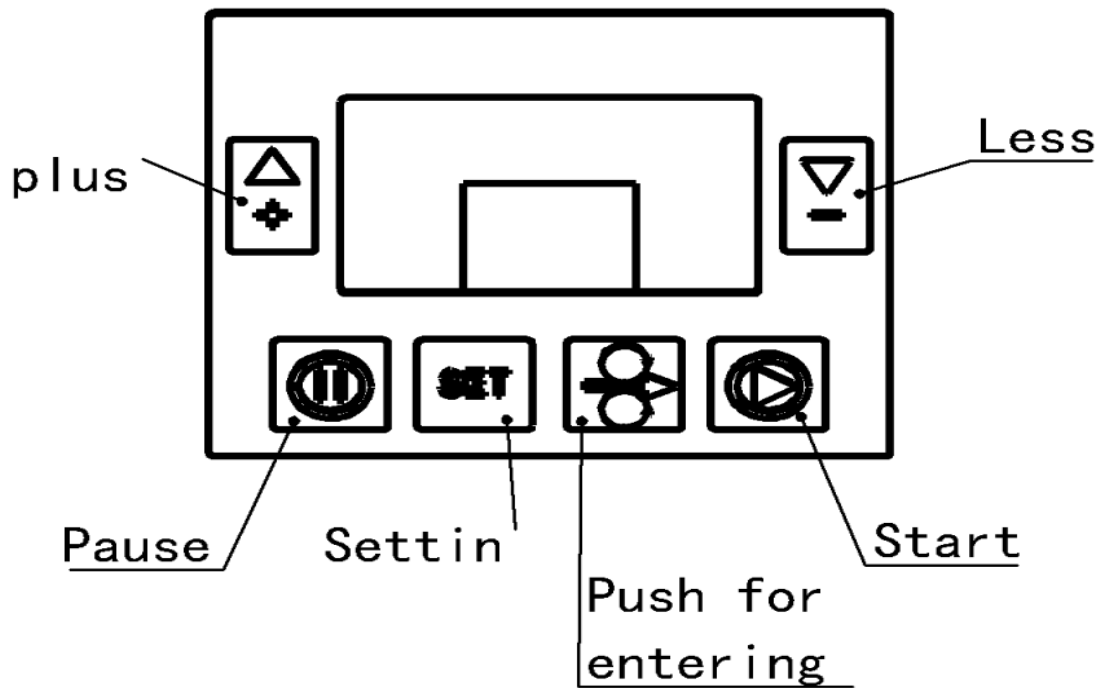

Pic 3(Operation Panel)

9.Safety Facilities (Pic 1)

2.2Certification

018N air filling machine have been certificated by CE.



3.0Introduction

3.1 System Introduction

018N is a lightweight and portable inflatable device, it's has beauty appearance and available for multi-use, its workable for cushion bag, gourd membrane and double row bag. Motor upgrade, brushless motor, high torque, long service life, up to 4000-5000 hours; Imported broadband power supply, suitable for 110V/220V voltage. Compared with the same price inflator, it has the characteristics of fuller inflation, more compact sealing, less noise and longer service life. It is the best choice for small factories with diversified types

Parameter

Dimension: 400MM*310MM*295MM (L*W*H)

Package Dimension: 495MM*430MM*390MM (L*W*H)

Net weight: 11.6KG

Weight: 14KG

maintenance service personnel can open.

During operation and loading material, please avoid direct touch to roller from finger, clothes, jewelry and hair.(tie hair up suggested).

3.Inflatable bag only suggest used as packing materials,do not use it as float, pillow, or child toy.

4.The weight of filling material(film) do not over 7KG,during material loading, do NOT stress it or leaning.

5.When the material is driven by the machine, static electricity will be generated. The material itself will also have static electricity. The operator cannot wear slippers or not wear shoes. Otherwise, the human body will become a conductor of static electricity, and feel like electric shock.

6.After long time operating the machine, if the film does not run smoothly or get stuck, please replace the blade in time.

7. After long time operating the machine, if appearance the sealing edge is not firm, broken seal edge, please confirm if the temperature proper, if the temperature belt broken, if yes, please replace it in time.

8.Speed and air volume of the air filling machine should adjust mutually, differ film have different parameter, no rated standard, need adjust the record according to the actual condition.

Attention: Do not running the machine without material! ! !

3.5 Power requirements

 **Warn:** Improper grounding may cause electric shock.

 **Warn::**Using with Wring board will be increasing the static electricity . the static electricity may cause operational problem and make the operator feel uncomfortable .

For normal operation , the power of 018N should be AC 86/264V , average current should be 2A , peak current should be 3.5A .Frequency 50 hz / 60 hz.Rated power 320W.The e machine has grounding wire, please use single-phase three-wire system power cord, the use of the grid must have a reliable grounding, otherwise static electricity cannot be discharged, the human body will become a conductor of static electricity, and feel like electric shock.

3.6 Film Storage

Warn: Please use the film produced by our company,if not so,may cause broken bag problems or influence the effect of the packing bag,and even damage the machine.

The temperature of storage should be 0-43°C.the film is available to stored in this range(0-43°C.exceed/below this range may damage the film).

Please noted,Before use,this film should in its operating temperature.

The films operating temperature range are 16-43°C . Please used the film within this temperature range to achieve the best sealing effect.

System Composition

1. Main power switch

The Main power switch located the back of the machine,function to turn on/off the system.

2. Start/Stop switch; NI switch

Press the switch during the running time of machine,and the machine will stop all the process of sealing,air filling and material feeding

3. Main power cord

Plug the power cord into the appropriate power outlet,more details please refer to 3.5 "Power requirements".

4. Control panel

The button panel: Used to set machine related values

Display screen: know all parameters of the machine

5. The side sealing

Inside are machine parts.

 **Warn:**Do not open the side cover,we only suggest its opened by our company representative and authorized maintenance personnel.

6 Film shaft

It is used to install the film coil, so that the film coil can be fixed and supported.

7. Heating strip

It is used to place the air pipe, blade and heating module, etc., which can heat seal the air bag after opening

 **Warn:**The roller temperature is very high, be careful of scalded

 **Warn:**Please careful and do not get rolled into the machine!

8. Film roll

Film rolls construct with (separate bag)pin holes film,available inflated and sealed by 018N.

9. Emergency stop switch

Do NOT use Emergency stop switch as pause/stop button.

4.0 Maintenance & Repair

4.1 Preventive maintenance

 **Warn:**Before maintain or repair the Q15,please do remember turn off the machine,and plug the Main power cord from the socket.

Maintenance cycle	Detail	Description
weekly	check&clean	open the belt cover of machine,blow off the dust; check if any abnormal abrasion machine component.

every month	contact	Arrange an on-site inspection; Contact the authorized distributor or our technical service representative to check the machine.
-------------	---------	--

4.2 Replace the blade

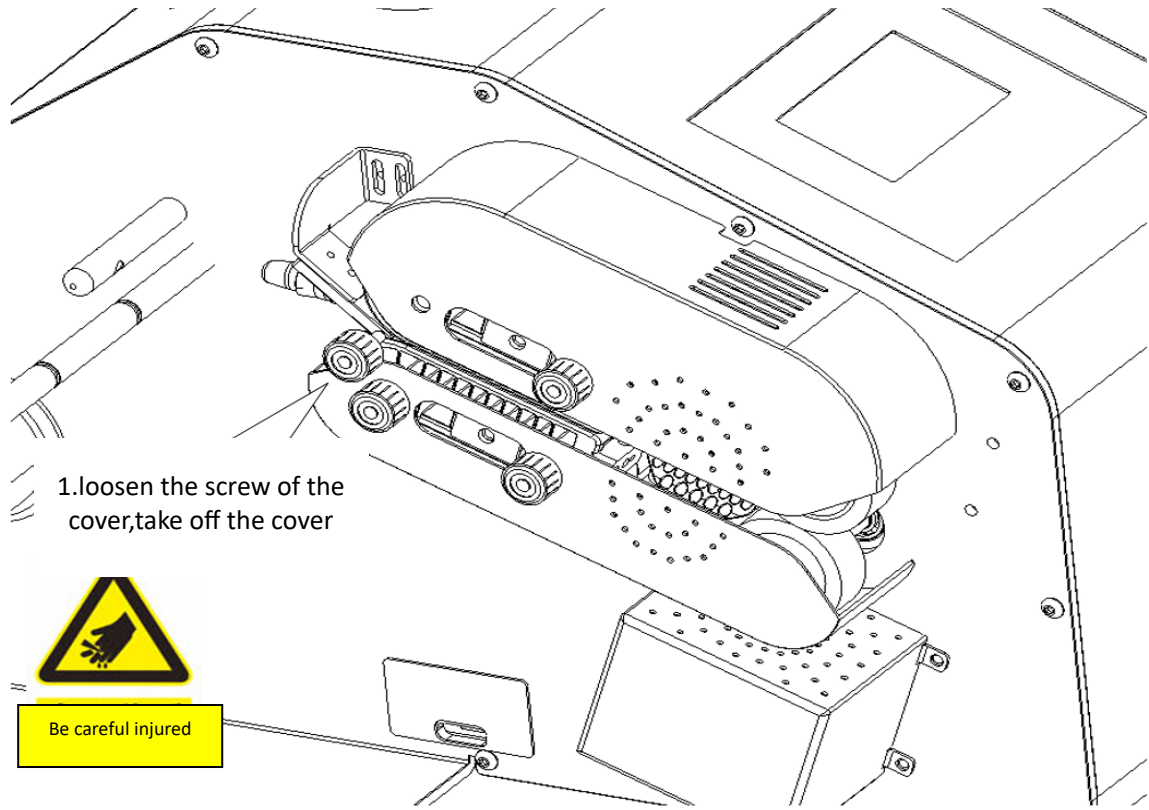

Pic 4(Tube replace and install instruction diagram 1)

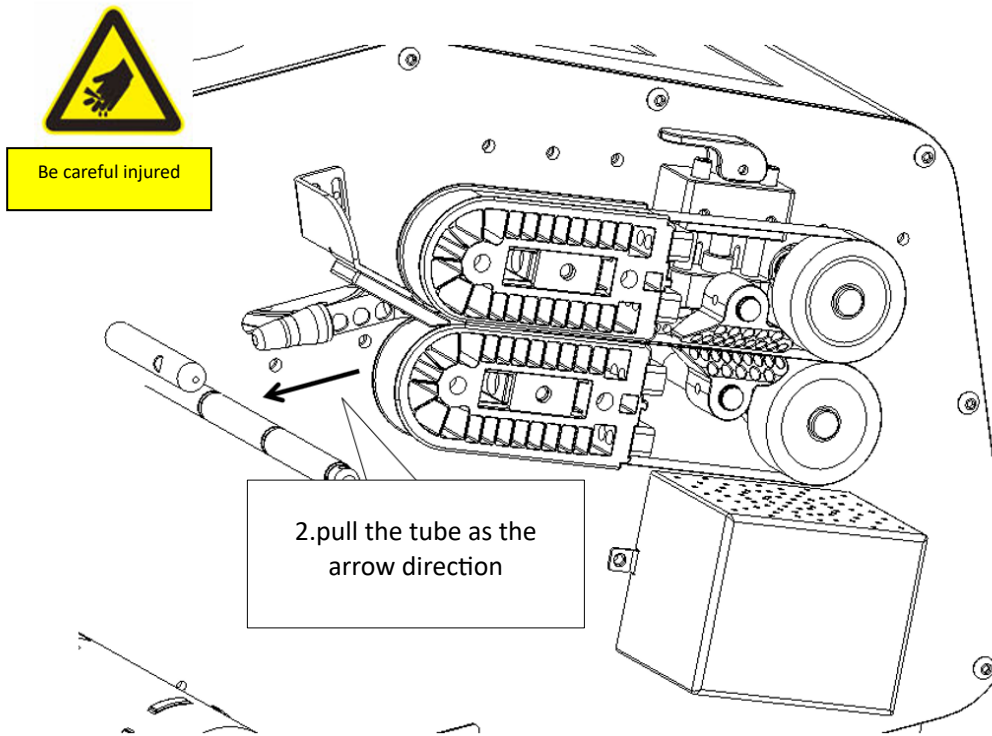

Pic 5(blade replace and install instruction diagram 2)

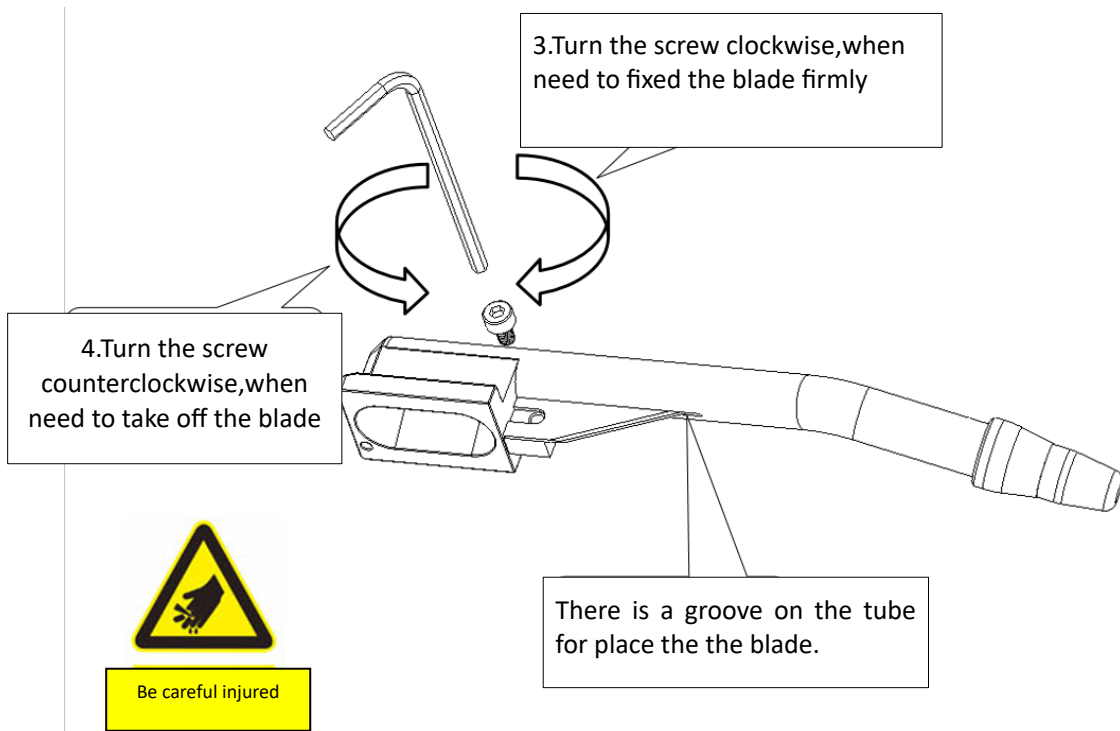

Pic 6(blade replace and install instruction diagram)

Remove the tube as pic 5 shown,Loosen the blade and fixed the screw to replace the blade(as pic 4 shown),then install the tube back.

4.3 Replace the high temperature belt

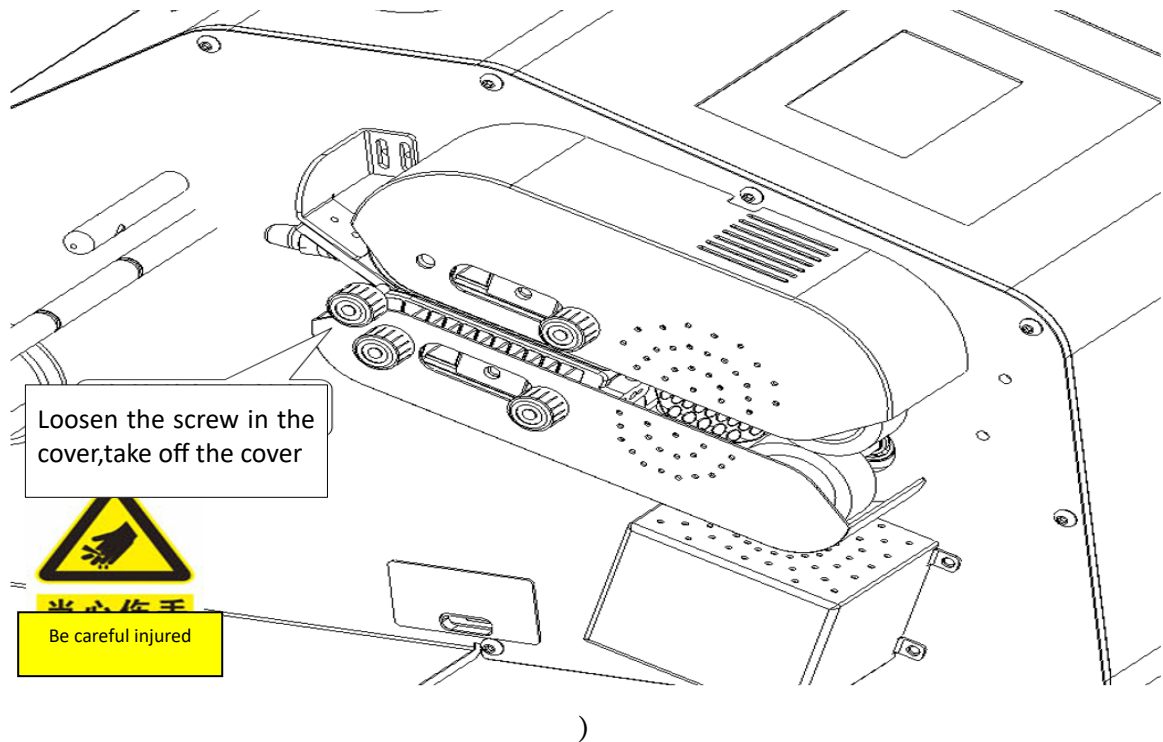

Pic 7(high temperature belt replace and install instruction diagram 1)

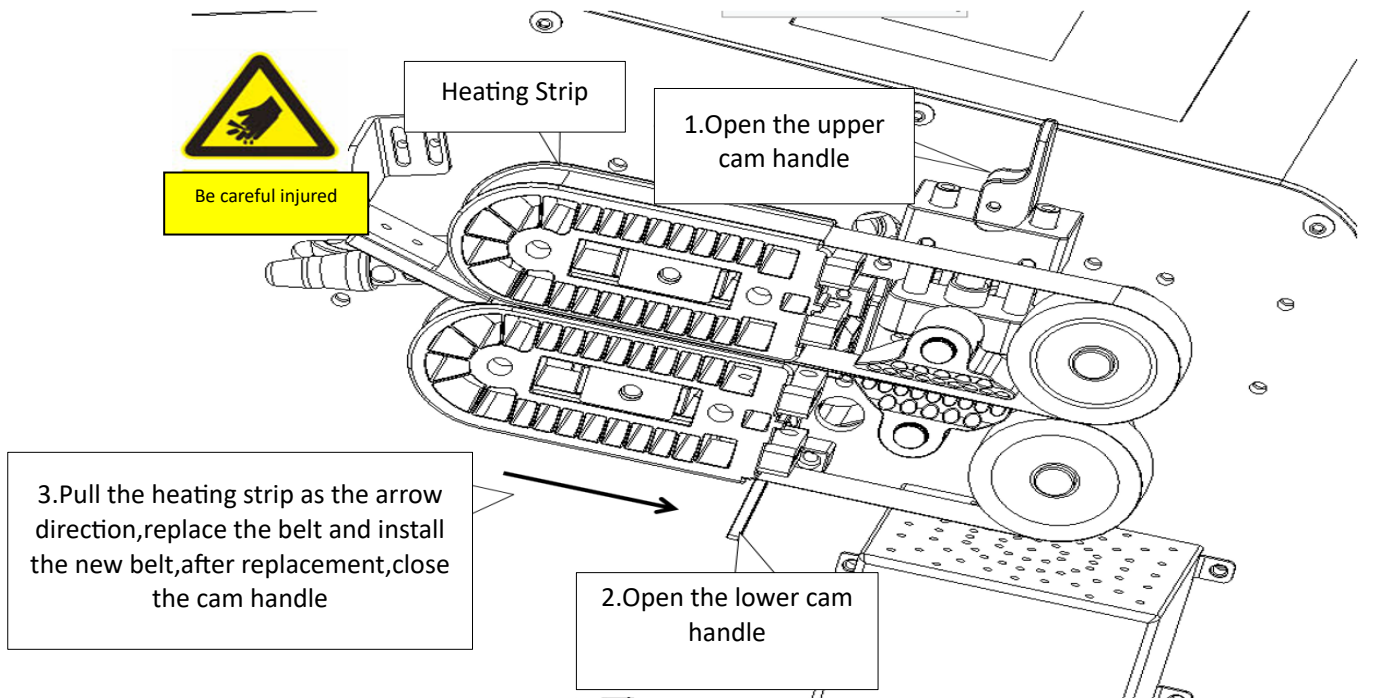

Pic 8(high temperature belt replace and install instruction diagram 2)

Loosen the cover screw and open the cover,open the upper and lower cam handles,push the heating strip to the direction of traction wheel,replace the belt,then close the cam handles,install the cover back.

4.4 Replace the high temperature adhesive tape

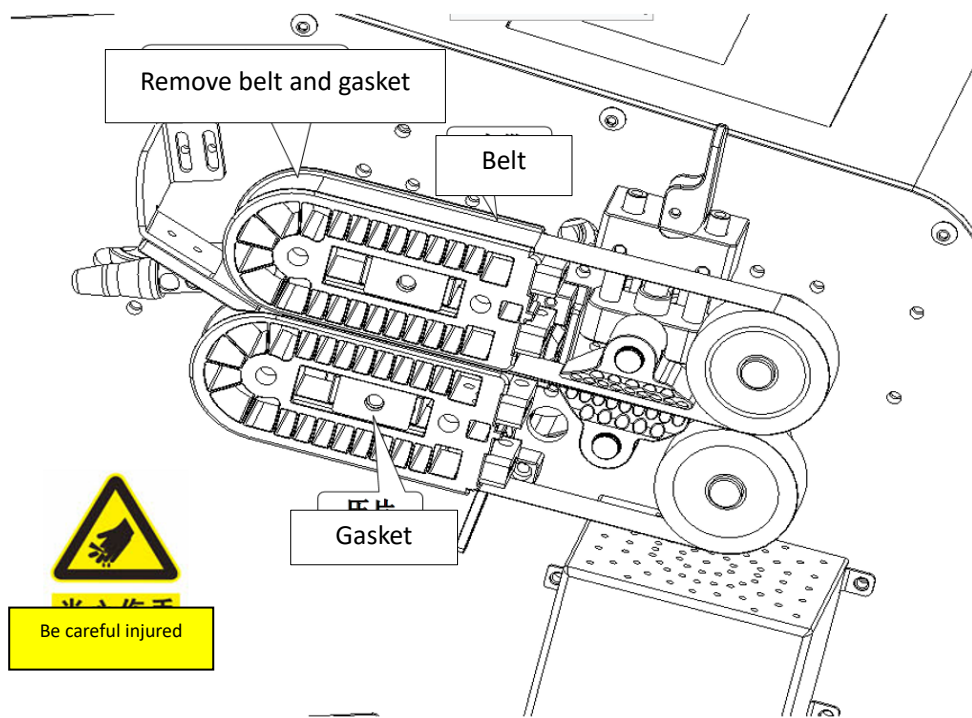
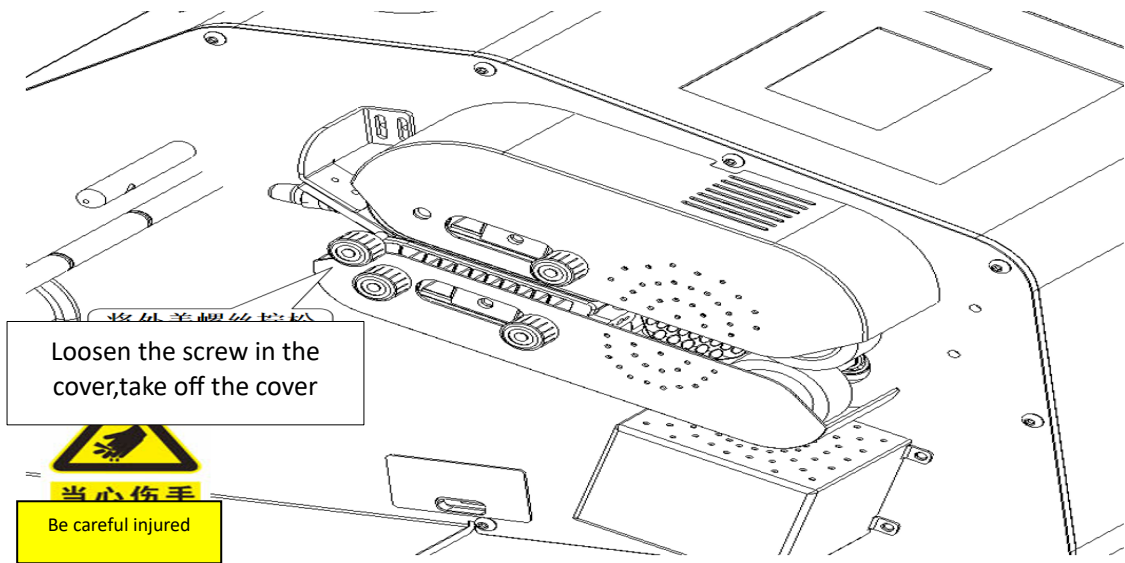

Pic 9(tape replace and install instruction diagram 1)

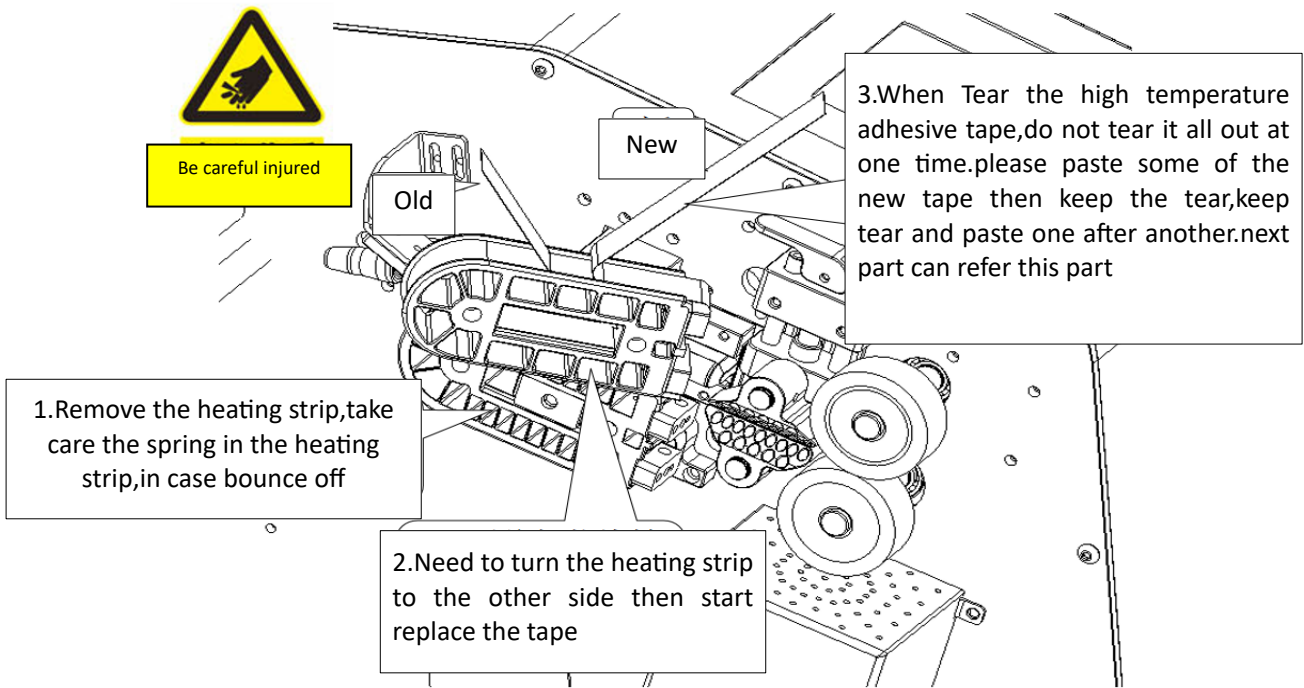

Pic 10(tape replace and install instruction diagram 2)

Remove the belt cover,push the heating strip to the direction of traction wheel(to make the belt loose),After belt been loose,then remove the belt,use screwdriver to loose the screw and gasket,which in the middle of heating strip;then remove the heating strip(noted:springs may slip out),tear the the high temperature adhesive tape and paste a new one,then install the heating strip,belt and belt cover back to the original position in proper order.